

# The "Beeper": An Audible Frequency Readout for the Blind Amateur



A BCD-output frequency counter, a decoder and an oscillator produce a tone to tell you when your transceiver is tuned to a predetermined frequency.

By Phillip S. Rand,\* W1DBM

When a blind ham wishes to tune a transceiver to a given frequency, he or she must rely on the 100-kHz crystal calibrator that is usually built into the rig. He will turn the tuning dial fully counterclockwise to the low-frequency end of the band. Next, he switches on the 100-kHz calibrator and, turning the dial clockwise, counts the 100-kHz beat notes until coming to the marker nearest the desired frequency. Finally, he counts dial revolutions, having previously found the number of revolutions per 100 kHz, and from that, the number of kHz per revolution (16 kHz per revolution on my Yaesu FT-101ZD).

By this method anyone can find, for example, 3716 kHz quickly and accurately by counting two beat notes plus one dial revolution, turning the dial in a clockwise direction. Some transceivers have frequency markers every 25 kHz, and also tune almost 50 kHz out of the band at each end.

With such a rig a blind ham must count 10 beat notes to reach 3700 kHz.

Suppose he wants to tune into a net on 3923 kHz. He must count 18 beat notes and continue tuning clockwise about 1-1/2 dial revolutions. He tries to locate the net by tuning around and listening for a familiar voice.

Some blind hams use an external 1-MHz crystal marker generator for finding band edges accurately. This is followed by several ICs to divide the frequency down to 100, 50, 25 or 10 kHz, as selected by a switch. Others use specially made crystals to serve as markers for their favorite frequencies.

## A Better Way

Having designed a visual frequency display previously,<sup>1</sup> I decided to convert this unit to an audible frequency display that could be used by visually handicapped amateurs. This device allows a ham with

impaired vision to tune his transceiver quickly and accurately to any frequency in any amateur band without counting beat notes or dial revolutions. The lead photo shows my "Beeper" along with the frequency counter described in note 1.

## Theory of Operation

Basically, the unit consists of 5 sections, as shown in Fig. 1. These are:

- 1) The up/down presettable BCD-output counter.
- 2) A decoder to change the BCD data into decimal form.
- 3) A set of three program switches for setting the desired frequency.
- 4) Two NOR gates and one NAND gate to provide the logic that determines when you have tuned to the programmed frequency.
- 5) A one-shot multivibrator that triggers an audio-frequency oscillator driving a miniature loud-speaker.

## The Up/Down Counter

The up/down, presettable counter is almost identical to my previous design ex-

\*P.O. Box 8, Haverhill, NH 03765

<sup>1</sup>Notes appear on page 24.

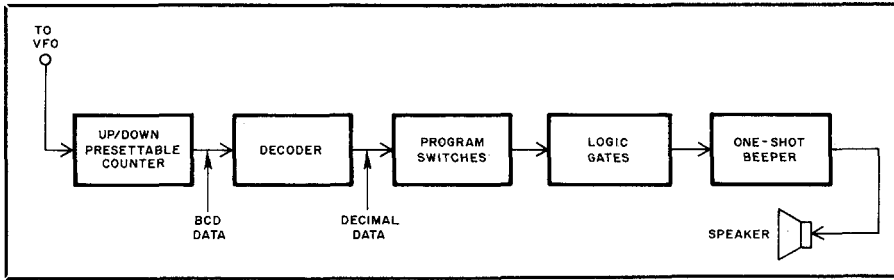
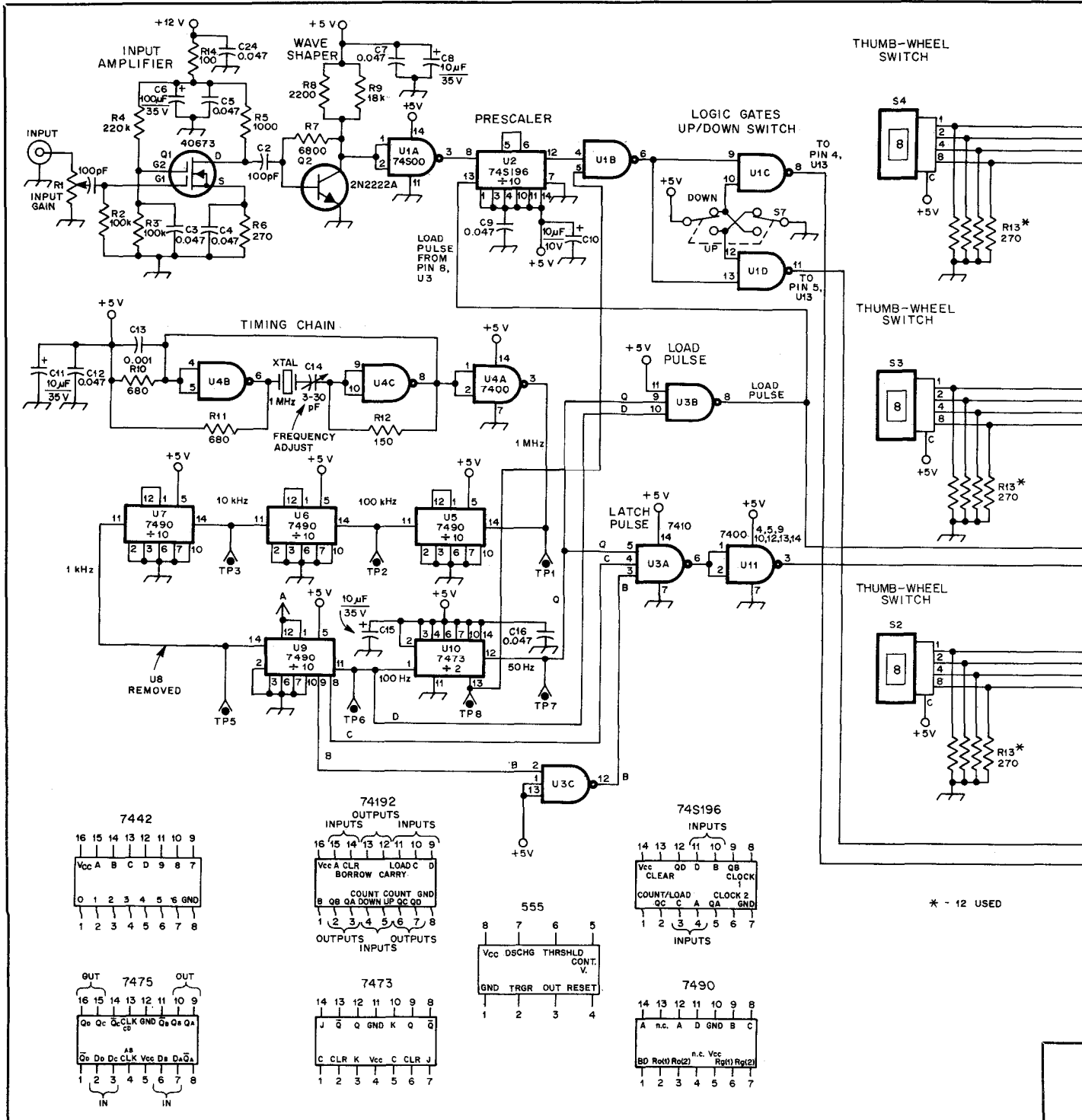

Fig. 1 — A block diagram of the audible frequency readout unit.

cept that to allow for a faster tuning rate, one divide-by-10 IC has been eliminated in the clock and a preset up/down counter has been eliminated from the counting chain. I can now turn the dial at a rate of 50 kHz per second instead of only 5 kHz per second.

As explained in note 1, an up/down presettable counter is necessary so the unit can be used with almost any transceiver regardless of VFO frequency or i-f. The only connection to the transceiver is a piece



of miniature coaxial cable to the VFO. A complete schematic diagram of the counter and readout is given in Fig. 2.

### The Decoder

The decoder consists of three 7442s that decode the BCD data for the three least-significant figures of the frequency. For example, a frequency of 14,303 kHz would be decoded as 303. You know that you are tuned to 14 MHz because of the position of the band switch on the rig. The counter does not read hundreds of hertz because it

would slow down the tuning rate and really is not necessary. Most nets and round tables operate plus or minus a few kilohertz as band conditions and QRM dictate.

Each 7442 has four BCD inputs and 10 decimal outputs. All outputs are high except the decoded one, which is low. A high is represented by +3.5 V or higher on the output pin of the IC, while a low is usually +0.3 V or less.

### Program Switches

The three frequency-programming

switches are one-pole, 10-position, non-shortening rotary switches. The output pins of each IC are connected to the 0 through 9 positions on a switch. Fig. 3 shows a means by which shorting-type switches can be used for the programming switches. The 0 through 9 positions of each switch are marked on the top panel with no. 2-56 machine screws so the blind ham can tell the position of the switch by feeling with his or her finger (Fig. 4). The left-most switch programs the 100s of kHz, the middle switch programs the 10s of kHz while

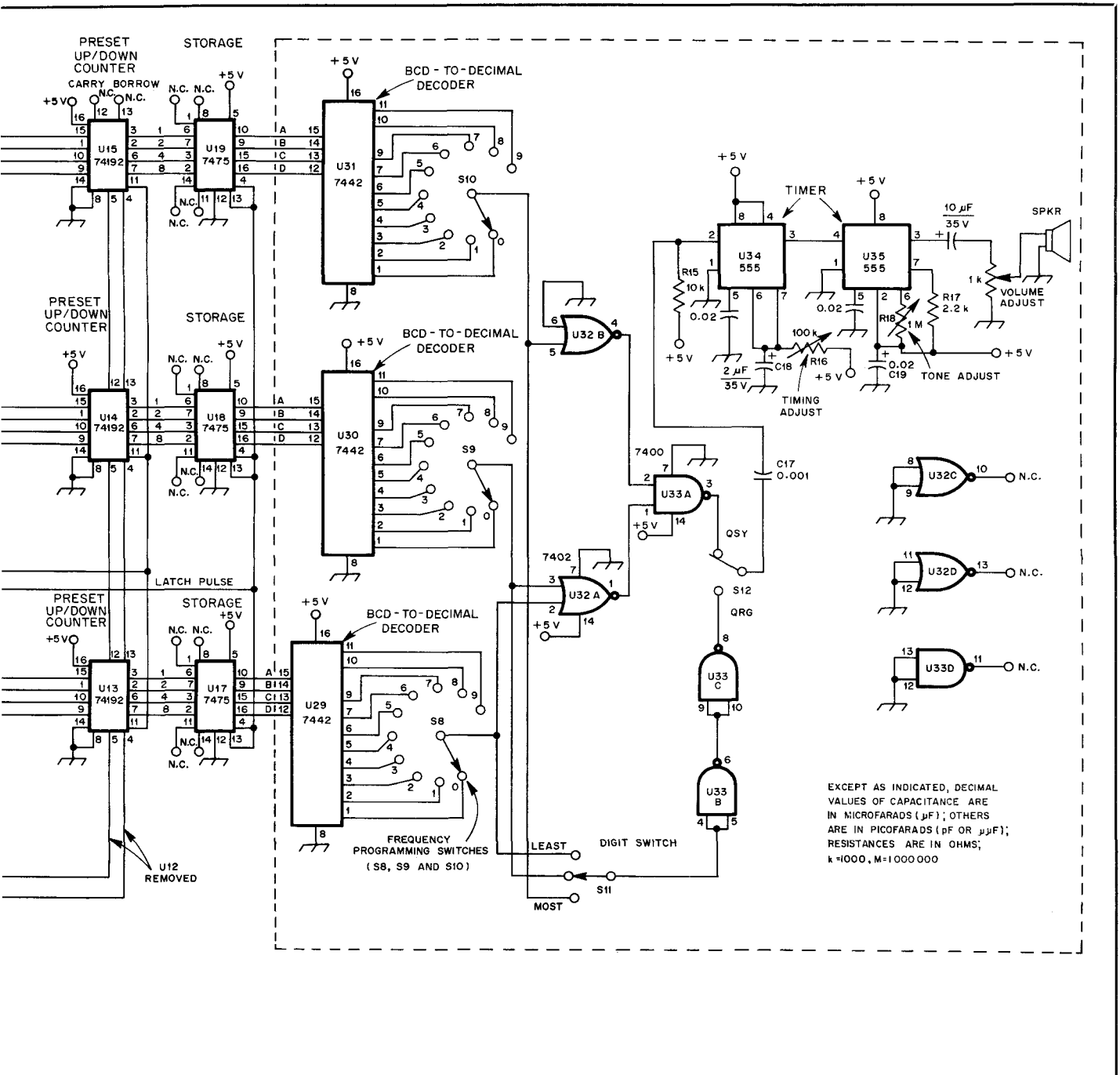

Fig. 2 — Complete schematic diagram of the frequency counter and audible frequency readout.  
 S2-S4 — Thumb-wheel switches, 0 to 9 BCD output.  
 S8-S10 — Single-pole, 10-position, non-shortening, rotary-type switches.  
 S11 — Single-pole, three-position rotary-type switch.  
 S12 — Spdt toggle switch.

EXCEPT AS INDICATED, DECIMAL VALUES OF CAPACITANCE ARE IN MICROFARADS (μF); OTHERS ARE IN PICOFARADS (pF OR μμF); RESISTANCES ARE IN OHMS, k=1000, M=1 000 000

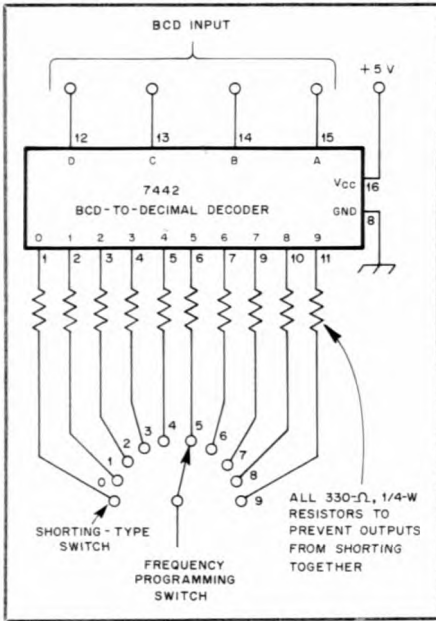

Fig. 3 — A method of using shorting-type rotary switches for the frequency-programming switches.

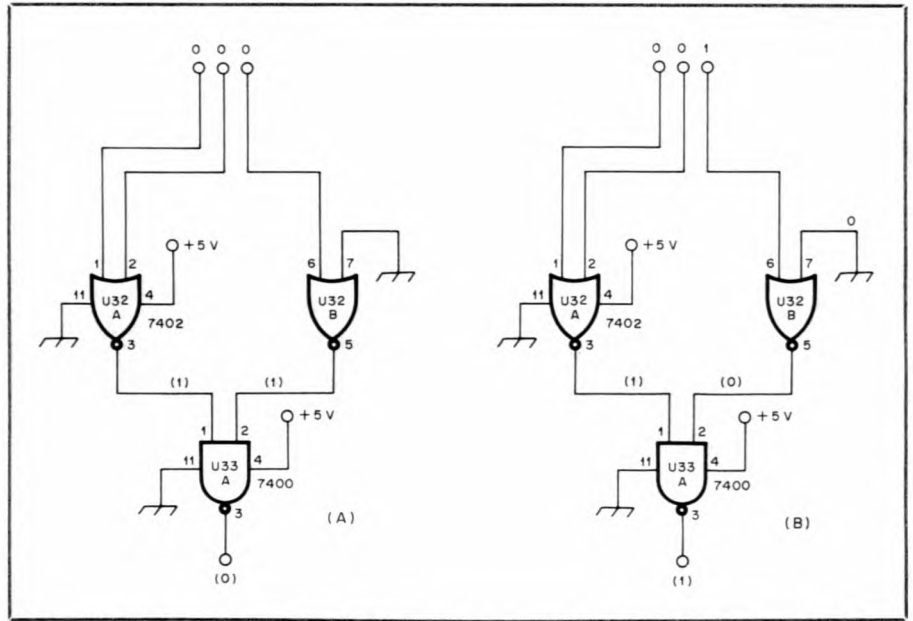

Fig. 5 — A three-input OR gate can be wired from two NOR gates and a NAND gate. The output from this gate when the transceiver is tuned to the programmed frequency is shown at A; B shows the output when the tuning is off by 9 kHz or less.

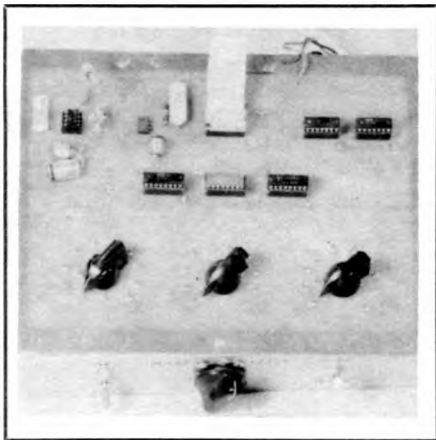

Fig. 4 — Photograph of the top panel of the decoder and beeper chassis. The three frequency-programming switches, with no. 2-56 machine-screw position markers, can be seen. No etched-circuit pattern is given because the wiring is simple, and experienced builders should be able to lay out a board if they desire to use one.

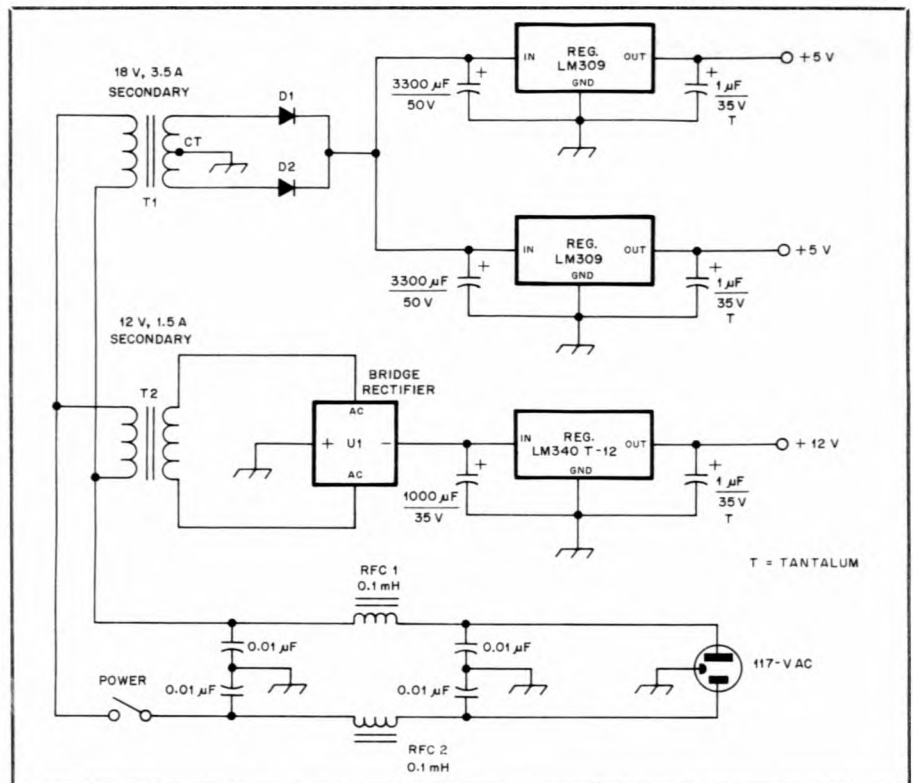

Fig. 6 — A schematic diagram of a power supply suitable for use with the complete audible frequency readout unit.

the right-most switch programs the units digit. The programmed output is taken from the movable contact on each switch and fed to the three gates.

### Logic Gates

A circuit is needed that will give a low output only when three lows are fed into it. This requires a three-input OR gate. Any output containing a high will be ignored by

the decoder. The OR gate is easily wired as shown in Fig. 5. A NOR gate output will be high only when both inputs are low. If one or both inputs are high, the output is low.

I have wired a three-input OR gate by using two 2-input NOR gates with one input tied to ground and then combining their outputs with a NAND gate. A NAND gate only

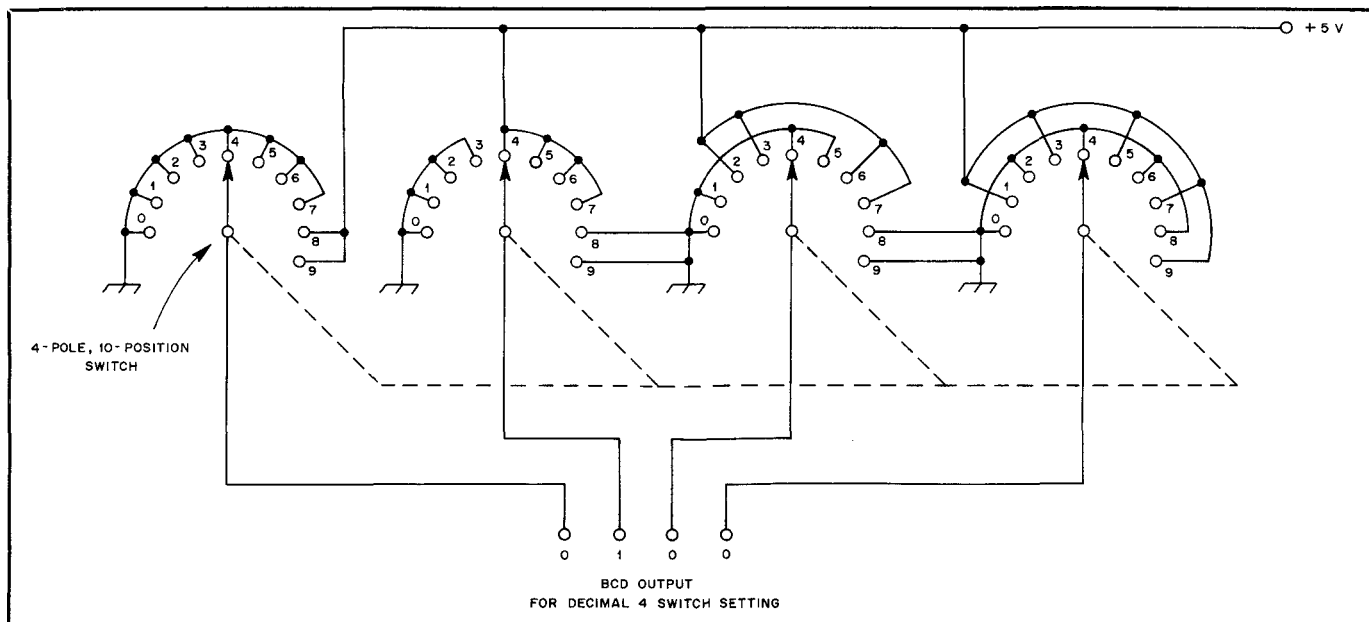

Fig. 7 — A method of wiring a four-pole, 10-position rotary switch to provide a BCD output is shown.

produces a low output when both inputs are high. Referring to Fig. 5A, note that when you have tuned to the programmed frequency, three lows are present at the input to the NOR gates, producing two highs at the input of the NAND gate and forcing its output low. Fig. 5B illustrates the situation when you have correctly tuned to the left and middle digits of your programmed frequency but are still as much as 9 kHz away from the exact frequency.

### The Beeper

We need a low output from the NAND gate to trigger the 555 one-shot multivibrator shown in Fig. 2. Since the output from the NAND gate is high up to the moment that you tune to the exact programmed frequency, and then falls to 0, C17 and R15 are used to differentiate this wave form to produce the necessary pulse for the one-shot. The output of the one-shot is timed by R16 and C18 for about 1/10 of a second and is fed to the control pin of the second 555, an audio-frequency oscillator that generates a tone in a miniature loud speaker. The tone of the beep is controlled by the values of R17, R18 and C19. R15 ensures that the voltage on pin 2 of the one-shot is always high except during the short interval of the trigger pulse. The trigger pulse always must be shorter than the one-shot output pulse.

### Construction

You have several choices in building this audible frequency readout. If you own a rig with a digital frequency display you may omit the counter portion and build only the decoder and beeper sections. In this case you must tap into the BCD lines with a 14-wire cable. This may be difficult because

of the compactness of modern solid-state transceivers and the fact that some use single-chip counters with no BCD output available. Generally, it is much easier to connect a short length of miniature coaxial cable to the VFO output and use an external counter.

If your rig does not have a built-in frequency counter, then you will need to build or acquire a suitable counter. If you elect to build the counter from scratch, the entire unit will fit on one 7- × 9-inch circuit board.<sup>2</sup> All the switches go on the front panel.

A power supply can be included in the cabinet. See Fig. 6 for the circuit diagram of a suitable supply. The power-supply requirements are reduced by not using the visual readout. A brute-force line filter is included to help prevent RFI problems.

If you already built the counter described in note 1, you may do as I did, and build just the decoder/beeper on a circuit board to be mounted on a separate 7- × 9- × 2-inch chassis. The Beeper is connected to the counter by means of a flat 16-wire cable with 16-pin DIP plugs on each end (a standard Radio Shack item). The new circuit board and switches could also be mounted directly over the counter. If you are using a circuit board from Circuit Board Specialists<sup>3</sup>, be sure to put jumpers from input to output across the spaces for the two divide-by-10 ICs that are not used. The BCD outputs are available at the input pins of the old 7448 sockets.

### Thumb-wheel Switches

Since we are using only three digits in the audible readout, three thumb-wheel switches are needed for presetting the up/down counters instead of the four used

in the original counter. If you cannot locate 0-to-9, BCD-output, thumb-wheel switches, you can make substitute switches from 4-pole, 10-position rotary switches by connecting them as shown in Fig. 7.

### Calibration

Calibration of the up/down presettable counter is necessary because the unit is designed to work with any rig that you may have, with or without a frequency display. When shifting from band to band, from upper to lower sideband or to cw, an additional adjustment of the thumb-wheel switches will be necessary.

To calibrate, simply tune to a known frequency containing three 0s (such as 7000 kHz) using the 100-kHz crystal marker. Now set the program switches fully counterclockwise to 000, place the QSY/QRG switch in the QRG position and set the three-position "digit" switch to the right, the least significant digit. Next, rotate the right-hand thumb-wheel switch until you hear a beep. Now set the digit switch to the middle position and rotate the middle thumb-wheel switch until you hear another beep. Finally, with the digit switch in the most significant position, fully counterclockwise, rotate the left thumb-wheel switch for a third beep. The counter is now calibrated for that particular band and mode of operation.

Next it is necessary to check for up/down counting. To do this, set the program switches to read 100 and then tune the rig to the next 100-kHz marker, turning the dial clockwise. If the unit beeps as you reach zero-beat, it means you are counting in the right direction. If not, you must change the up/down switch and repeat the calibration. Rigs such as the Heathkit

HW-101, Yaesu FT-101 and others using the same conversion logic require the switch to be in the count-down position. This need only be checked once for your rig.

### Using the "Beeper" to QSY

To tune rapidly from one part of a band to a net frequency, simply program the desired frequency with the three switches, set the QSY switch and crank the dial one way or the other until you hear a beep. If you were tuning fast you probably overshot the mark, so tune slowly in the other direction a few kilohertz until you hear another beep. You are now on frequency, plus or minus 1 kHz if you calibrated the up/down counter for the band and mode of operation in your particular transceiver.

### QRG? What Is My Frequency?

To read the frequency you are tuned to, it is necessary to question each digit, one at a time. This is not as hard as it sounds because you usually know about where you are tuned: You may only have to question the least significant digit. For example, set the QSY/QRG switch to QRG, set the digit switch to the right (the least significant digit) and rotate the right-hand program switch until you hear a beep. Let's assume you are working in the General class portion of the 20-meter phone band and you think your frequency is somewhere between 14,300 and 14,310 kHz. You determine by feeling the screw heads with your finger that the switch is in the 3 position. It's a pretty good bet that you are on 14,303 kHz. It could not be 14,403 or 14,203 but perhaps it is 14,313. To be sure, set the digit switch to the middle position and rotate the middle program switch for a beep. Your finger tells you that the second digit is in fact a 0. If you want, you can also confirm that the left-hand digit is a 3. Of course the 14 MHz is determined by the band switch on the rig.

### Conclusions

I gave some thought to using a voice synthesizer to produce an audible frequency readout, but this seemed to be a needless complication. Most operators would not want to move a few kilohertz, wait for a voice announcement of the frequency and tune a few more kilohertz, repeating this procedure until finally reaching the desired frequency. The circuit required for a voice synthesizer would be more complicated, and construction of the unit would be more difficult. The device just described is simple to build and easy to use. It enables a ham with impaired vision to tune to any desired frequency quickly and accurately.

### Notes

<sup>1</sup>Rand, "A Versatile Digital Frequency Display," *QST*, Nov. 1977, page 21.

<sup>2</sup>mm = in.  $\times$  25.4

<sup>3</sup>Circuit boards and complete parts kits for the original frequency counter and the audible frequency readout are available from Circuit Board Specialists, P.O. Box 969, Pueblo, CO 81002. 

# Strays

### TEACHING THROUGH AMATEUR RADIO

Have you ever participated in a historical event, or met a famous person? Why not tune to 21.395 MHz between 1200 and 2100 UTC Monday through Friday, and share that experience with members of the NYC Junior High School No. 22 ARC? See the difference you can make in a youngster's education. — *Joseph J. Fairclough, WB2JKJ, New York, New York*



Wayland "Soupy" Groves, W5NW (left), of Odessa, Texas, was honored recently with a party put on by the members of the West Texas ARC in recognition of his 60 years of membership in the ARRL, 35 of which were spent on the Board of Directors. Helping Soupy celebrate were club President K5IID (center) and ARRL West Gulf Division Director W5EDZ. (photo by Rainey)

### MOVING, CHANGING CALL?

When you change your address or call sign, be sure to notify the Circulation Department at ARRL Hq. Enclose a recent address label from a *QST* wrapper if at all possible. Address your letter to Circulation Department, ARRL, 225 Main St., Newington, CT 06111. Please allow six weeks for the change to take effect. Once we have the information, we'll make sure your records are kept up-to-date so you'll be sure to receive *QST* without interruption. If you're writing to Hq. about something else, please use a separate piece of paper for each request.

### IHN HAS NEW MANAGER

Cal Burt, KA0DFN, is the new manager of the International Handicappers' Net, succeeding Ray Meyers, W6MLZ, sponsor of the IHN for the past 25 years. KA0DFN, a retired Air Force colonel, was recently appointed to the President's Committee for the Employment of the Handicapped. Membership in the IHN costs but a letter stating your call sign and the nature of your handicap, and a business-size s.a.s.e. to hold your certificate. For more information, write to Cal Burt, KA0DFN, P.O. Box 59, Oregon, MO 64473.

### INTERESTED IN LEAGUE-SPONSORED INSURANCE?

The Membership Affairs Committee is studying the feasibility of offering League members additional insurance programs beyond the present ARRL Ham Radio Equipment and Club Liability programs. Participation in the plans would be voluntary. Please take a few moments to complete the following questionnaire and send it to the Membership Services Department, ARRL, 225 Main St., Newington, CT 06111. Make a photocopy if you'd like, or simply answer the questions on a separate piece of paper. Thanks.

I would be interested in the following types of voluntary insurance plans, should the ARRL offer them:

	I am	
	interested	not interested
1) Life Insurance	<input type="checkbox"/>	<input type="checkbox"/>
2) In-Hospital Insurance (to pay a fixed amount each day during hospitalization)	<input type="checkbox"/>	<input type="checkbox"/>
3) High-Limit Accident Insurance (to pay specified amounts for specific levels of injury due to accident)	<input type="checkbox"/>	<input type="checkbox"/>
4) Disability Income Protection	<input type="checkbox"/>	<input type="checkbox"/>
5) Excess Major Medical (to pay medical charges above a deductible of \$15,000 to \$25,000)	<input type="checkbox"/>	<input type="checkbox"/>
6) Major Medical (to pay medical expenses above a deductible of \$500 to \$1000 but with a maximum benefit of \$20,000)	<input type="checkbox"/>	<input type="checkbox"/>

I do not believe the ARRL should sponsor insurance programs that have no direct relation to Amateur Radio.

Please note: An expression of interest in no way binds you to a particular course of action. This survey is designed only to gauge membership interest in these insurance programs.



# Feedback

□ Author Wingfield has found several printing errors in his "New and Improved Formulas for the Design of Pi and Pi-L Networks" (Aug. 1983 *QST*). In the program listing, the last term of line 180 should read:  $(Q1*Q1+1)$ : GOTO 280. Also, line 220 should begin with: IF  $R1/R2 > \dots$

On page 24, the first full sentence should begin, "The error is greater for  $R1 < R2, \dots$ " There is a reference to Motorola AN-267 in the last paragraph under the "Unsatisfactory Q Results" subheading; the data mentioned actually appears on page 6 of AN-267, not at the beginning.

Eq. 13, on page 25, should read:

$$Q1 = \sqrt{\frac{Qo \cdot R1}{X_L} - 1}$$

and the term "1" in Eq. 14 should be included under the radical sign. Eq. 67, at the upper-right corner of p. 28, should read:

$$Q2 = Qo - Q1$$

□ Bob Shriner, WA0UZO, points out an error in Fig. 2 of Rand's article, "The 'Beeper': An Audible Frequency Readout for the Blind Amateur," on p. 21 of Sept. 1983 *QST*. Timer U35 will not work as shown. Pin 2 should be connected to pin 6, not to +5 V as shown. Make the connection to the top of the 1-M $\Omega$  tone-adjust control, instead of the bottom.

□ Author Gannaway, G3YGF ("Tropospheric Scatter Propagation," Nov. 1983 *QST*), informs us that his address has changed to 31 High View, Pinner, Middlesex, HA5 3PE, England.

□ More errors have been found in, "The Pizza Clock: An Exercise in Wire Wrapping" (June 1983 *QST*; Feedback p. 50, Dec. 1983 *QST*). The 1-k $\Omega$  resistor at pin 6 of U1 has not, as stated in the Dec. 1983 Feedback, been eliminated;

rather pins 5 and 6 are reversed in Fig. 7, on p. 30, of the article. U5 and U9 are 4069 CMOS hex inverting buffers, not 4049s.

□ WA1RGP tells us that the statements about safe gate swing in "A VXO CW Rig for 30 Meters," by DeMaw (Nov. 1983 *QST*), are in error. Siliconix no longer includes a gate-protection diode in the VN67AF. Caution is suggested; some of the older devices are still sold through retail outlets.

□ Vinton Brown, W6TDA, points out an error in "The Manufacture and Use of Resistors" (Nov. 1983 *QST*). The top line of the second column on page 24 should read, "... so the resistance will not increase with increasing frequency." Actually, other construction factors are involved, and the resistance may increase or decrease with increasing frequency. This will depend on the actual resistance, and probably even the manufacturer. The general trend is for the resistance to decrease slightly as the frequency increases above some threshold, typically 10 MHz.

□ The correct address for Austin Custom Antenna (Product Review, *QST*, Dec. 1983) is: P.O. Box 357, Sandown, NH 03873.

□ The review of the A.E.A. AMT-1 AMTOR Terminal Unit (Product Review, Nov. 1983 *QST*) requires a bit of clarification. In the review, mention is made of using the low tones of 1275/1445 Hz and operating the transceiver in the USB mode. The review unit is one of the first distributed in the U.S. and, as such, uses the low tones. Later units sold in the U.S. use the high tones of 2125/2295 Hz and require use of the LSB mode.

□ A line was inadvertently dropped from the article on the Volunteer Examining Program in Dec. 1983 *QST* (bottom of first column, page 51). The missing line reads: [condi]tions are met: "BE IT RESOLVED that the ... QST